

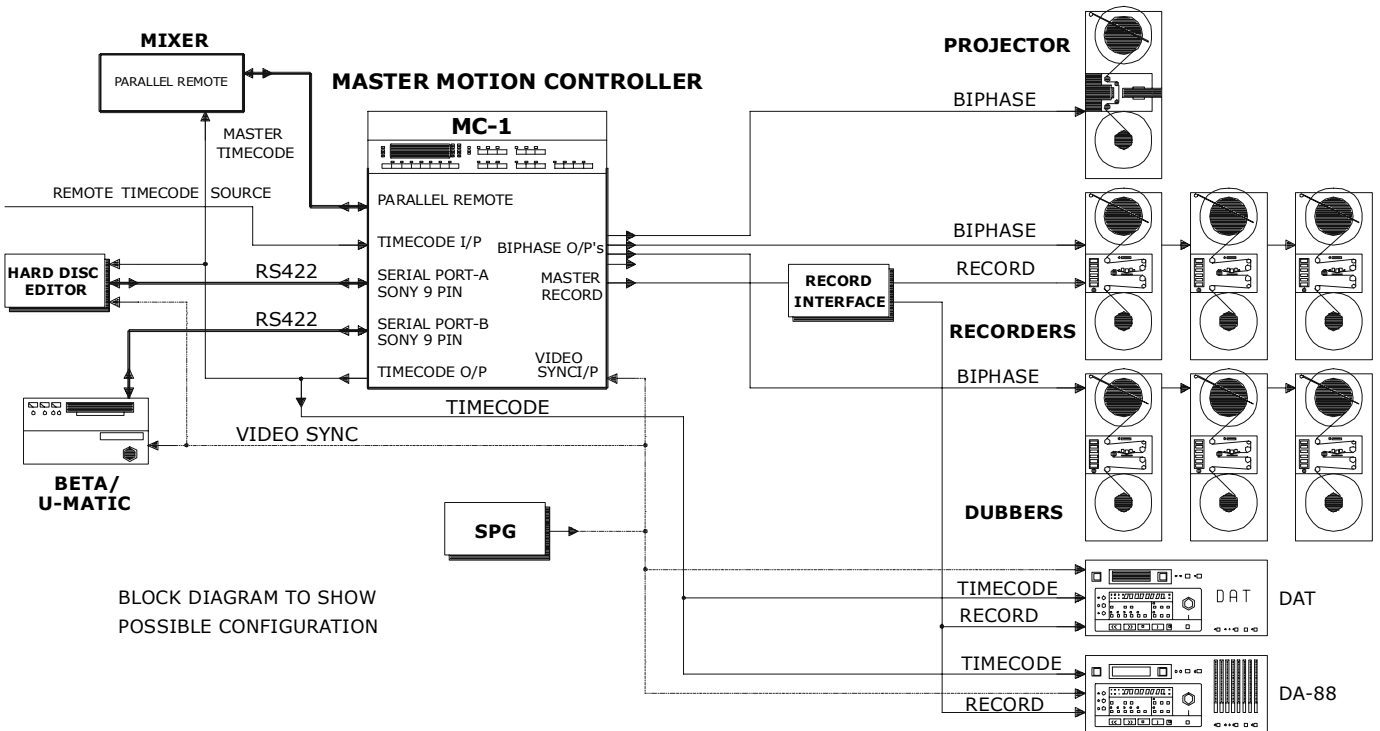

Bi-Phase & Timecode Virtual Master MC-1

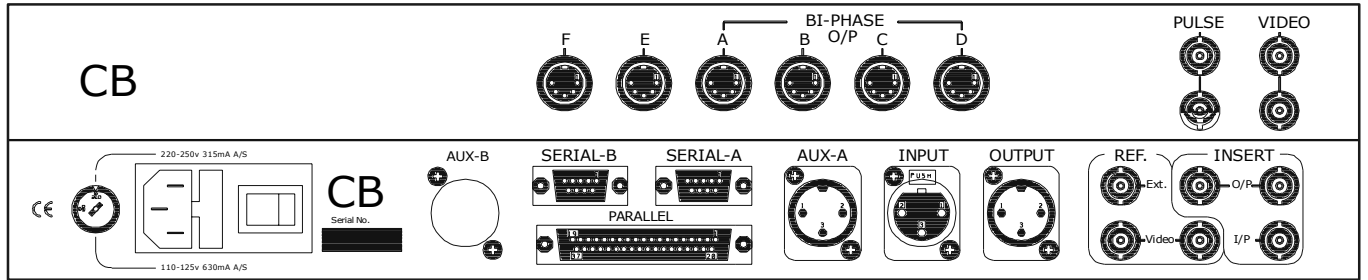
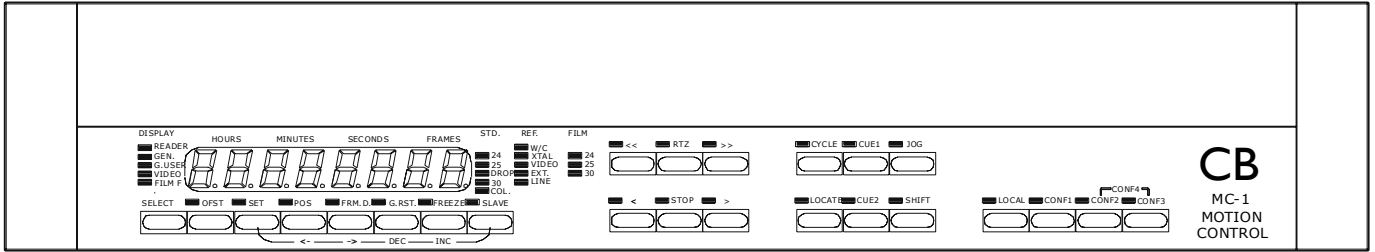

- **Four Bi-Phase Outputs** 1, 2, 4, 5, 10, 20, 50 or 100 Pulses per Frame
- **Timecode Output** Any standard
- **Electronic Gearbox** 24:25:30
- **External Reference Input** Mains, Video, TTL frame rate
- **Parallel Remote Control** Full function including JOG
- **Tapeless option** Instant locates for use with Hard Disc Systems
- **Serial Remote Control Input** Sony 9-pin protocol
- **Serial Remote Control Output** Slaving a VTR using Sony protocol
- **Synchronize to Timecode** Any frame rate
- **Parallel Track Arm Output** 16 Record On and 16 Record Off
- **Additional Bi-Phase Output** Always at 25 fps
- **Tach and Direction Output**

MC-1 MASTER MOTION CONTROLLER: 9-pin serial remote: Parallel remote: 4 Bi-Phase outputs: Timecode output: 9-pin serial video synchronizer Slave to timecode: 16 Track Record Arming: One Bi-Phase output always at 25 fps: Tach + Direction Output